

## Obstacle Avoiding Robot

Dr. Meena Chavan, Amit Kumar, Hitesh Saini, Gaurav Kale  
*Bharati Vidyapeeth (Deemed To Be University), College Of Engineering,  
Pune, India.*

---

**ABSTRACT-** *Obstacle detection and avoidance can be considered as the central issue in designing mobile robots. This technology provides the robots with senses which it can use to traverse in unfamiliar environments without damaging itself. In this paper an Obstacle Avoiding Robot is designed which can detect obstacles in its path and maneuver around them without making any collision. It is a robot vehicle that works on Arduino Microcontroller and employs two ultrasonic distance sensors to detect obstacles. The Arduino board was selected as the microcontroller platform and its software counterpart, Arduino Software, was used to carry out the programming. The integration of two ultrasonic distance sensors provides higher accuracy in detecting surrounding obstacles. Being a fully autonomous robot, it successfully maneuvered in unknown environments without any collision. The hardware used in this project is widely available and inexpensive which makes the robot easily replicable and use.*

**KEYWORDS:** *obstacle avoidance, ultrasonic sensor, arduino microcontroller, avoiding robot, arduino software*

---

Date of Submission: 25-05-2021

Date of acceptance: 07-06-2021

---

### I. INTRODUCTION

From its initiation in the 1950s, modern robots have come a long way and rooted itself as an immutable aid in the advancement of humankind. In the course of time, robots took many forms, based on its application, and its size varied from a giant 50 feet to microscopic level. In the course of technological developments of robots, one aspect remained instrumental to their function, and that is mobility. The term “obstacle avoidance” is now used in modern robotics to denote the capability of robot to navigate over an unknown environment without having any collision with surrounding objects (Duino-Robotics, 2013).the Future

This project developed an obstacle avoiding robot which can move without any collision by sensing obstacles on its course with the help of two ultrasonic distance sensors. Robots guided with this technology can be put into diversified uses, e.g., surveying landscapes, driverless vehicles, autonomous cleaning, automated lawn mower and supervising robot in industries. The robot developed in this project is expected to fulfill the following objectives:

- The robot would have the capacity to detect obstacles in its path based on a predetermined threshold distance.
- After obstacle detection, the robot would change its course to a relatively open path by making autonomous decision.
- It would require no external control during its operation.
- It can measure the distance between itself and the surrounding objects in real-time.
- It would be able to operate effectively in unknown environment.

Investment Summit in Riyadh, a robot called Sophia-Robot 2017 and referred to with female robot got Saudi Arabian citizenship, becoming the first robot ever to have a nationality Obstacle avoidance in robots can bring more flexibility in maneuvering in varying environments and would be much more efficient as continuous human monitoring is not required.

### II. RELEVANT WORKS IN OBSTACLE DETECTION AND AVOIDANCE

To date, there have been a number of successful attempts in designing obstacle avoiding robots. These works differ by selection of sensors, path mapping process and the algorithms applied to set the operational parameters. There have been numerous projects in this arena using laser scanner, infrared sensor, GPS and multiple sensors to accomplish obstacle detection and avoidance.

Researchers are persistently trying to find more precise ways to develop autonomous robot or vehicle

movement technology. In obstacle detection, the selection of sensor is vital for the required application of the robot, otherwise it might fail to operate even though all hardware and software are working properly. For example, a robot with optical sensors in a room with glass walls might create more collisions than avoidance. Hence sensors should be selected in accordance with the characteristics of the obstacles. Ryther and Madsen (2009) used 240° laser scanner as a sensor to build a robot based on Small Mobile Robot (SMR) platform. The robot generates a collision free path from a grid map using wavefront algorithm (Fig.1).

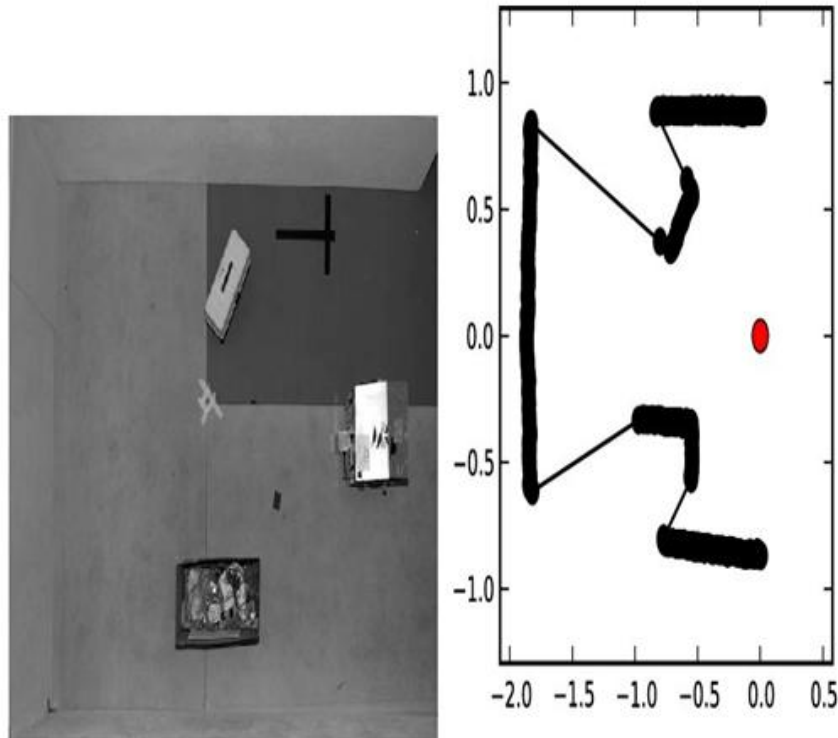

**Fig.1:** Obstacle Avoidance Setup and the Resultant Grid Map with the Collision Free

The robot developed in this project uses ultrasonic sensors to detect obstacles in real time and requires no path planning. Its processing unit is based on the Arduino platform. The Autonomous Surface Vehicle (ASV) developed by Heidarsson And Sukhatme (2011) employed a single-beam mechanically-scanning profiling sonar to detect obstacles under water. The profiling sonar has the ability to produce cone-shaped beam which is ideal for detecting near surface obstacles. One of the objectives of their work was to investigate the suitability of using sonar near the water-air boundary for which the study found promising results. Although similar detection technology is used, our robot is designed to work on the ground and detect obstacles above the surface. It uses the Arduino software which enables to upload a code written in C programming language.

There were other works using multiple sensors to make the robot more accustomed to its surroundings by employing both range and appearance based obstacle detection. Their obstacle detection also includes a combination of global and local avoidance. In one of these projects, Hasan and Mahmud (2013) fused the strengths of an image and an ultrasonic sensor to detect objects and measure its size. Detection of object was carried out by the ultrasonic sensor and its measurement required the help of a camera. The code was designed to receive the distance to object, its height and width.

This project employs multiple sensors, but unlike the last example, we used the same sensors for enhancing the horizontal range of searching obstacles. These ultrasonic distance sensors work in combination to measure distance to the surrounding objects and detect the presence of obstacles if they are within the threshold distance. The inclusion of two sensors of the same kind provides more accuracy in obstacle detection as it widens the field of searching so we keep it in a Wide position to cover the large distance.

### III. WORKING PRINCIPLE

The robot in this project detects obstacles with the help of two ultrasonic distance sensors to measure the distance to surrounding objects. Although the project is started with a single ultrasonic sensor, two more sensors are added since the robot had blind spots in its right and left direction for which it was having collision while maneuvering. Unlike the projects discussed above, our project concentrates on coordinating multiple ultrasonic sensors for maneuvering without collision and also maintaining a minimum travel distance. Fig.2 describes this algorithm in a flow chart.

The robot was designed to detect the presence of any object within the specified threshold distance. If any object is found within this distance, it is designated as an obstacle and the robot will turn away from it.

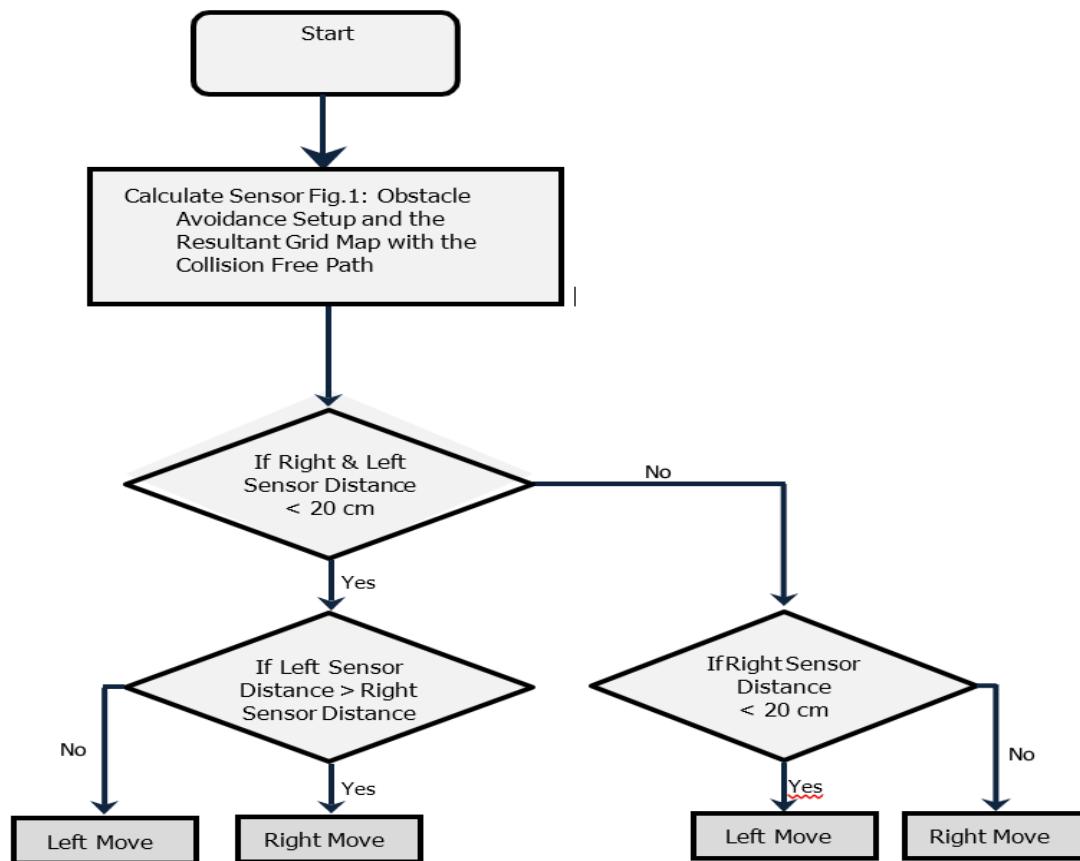

**Fig. 2:** Algorithm for Obstacle Avoiding Robot

The two ultrasonic sensors are placed in the frontal section of the robot at the right and left position. The two sensors emit an ultrasonic pulse every 300 ms which echoes from the neighboring objects. Using time difference between the input and echo, the Arduino calculates the distance to the obstacle from which the echo is coming by using the constant speed of sound 340 m/s. When one of the sensors detects obstacle within the threshold distance, the robot changes its direction. Along with these basic movements, the robot is designed to handle a more complex situation when all three sensors have obstacles within the specified range. In this case, the robot will move backward for 12 ms and again check the distance to objects with the help of right and left sensors. The robot will then compare the two distances and move in the direction where the distance is larger.

#### IV. ROBOT ARCHITECTURE AND PROGRAMMING

##### a) The Arduino Platform

There are numerous hardware platforms in use based on which obstacle avoiding robots or in general mobile robots are built. We have selected the Arduino board as the microcontroller platform and its software counterpart to carry out the programming. Arduino is an open-source platform which is an integration of hardware (microcontroller) and software components. The microcontroller can read input in the form of light or sound through a sensor and convert it into an output (e.g., driving a motor) according to the instruction given by the Arduino programming (Arduino, 2021).

The Arduino microcontroller can only be functional with the help of a code. To write this code.

##### b) Hardware Components and Assembly

The following flowchart in Fig.3 shows the hardware used to build the robot and explains relationship (input and output) among them.

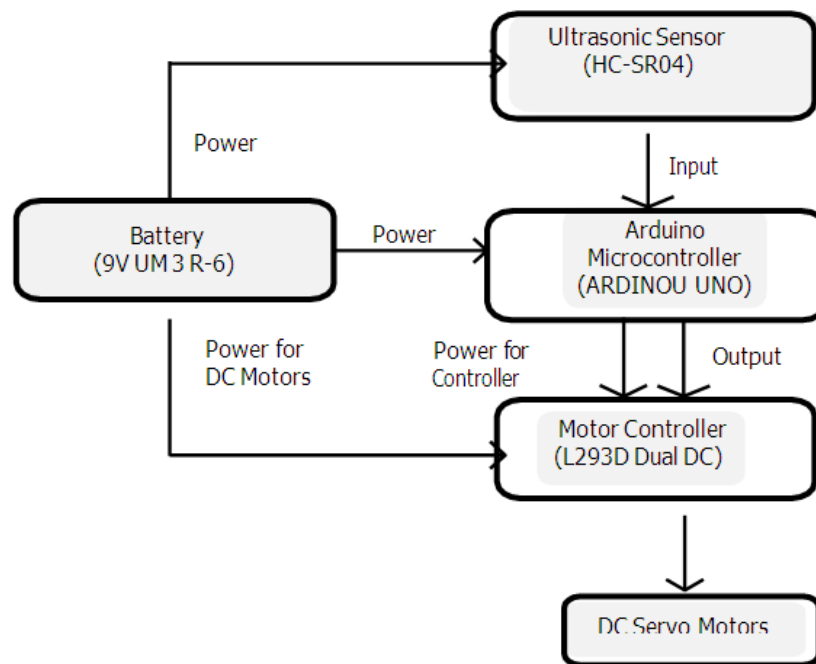
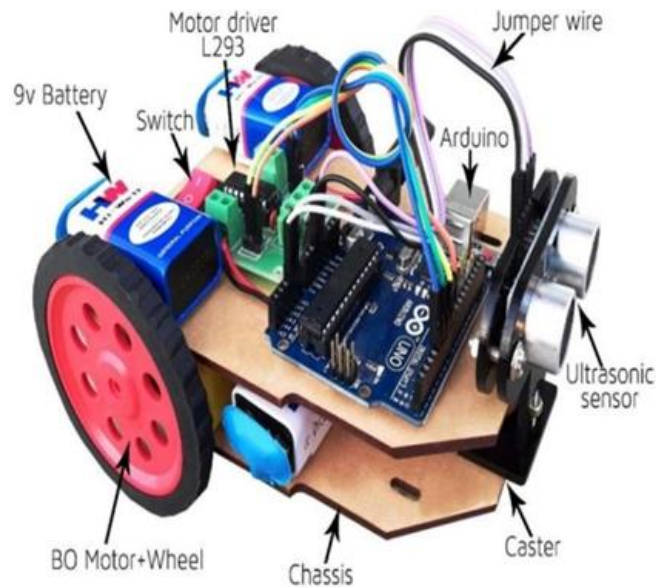

Fig.3: Algorithm for Obstacle Avoiding Robot

Arduino Integrated Development Environment or Arduino Software (IDE) is used which is also open-source like the Arduino Uno board (Arduino, 2021). It is much popular software used by many for its simplicity and the ability to communicate with all Arduino boards. Arduino Software version 1.8.3 2017.05.31 is used to write the code in C programming language which is then uploaded to the Arduino microcontroller through an USB cable. The software saves the code in a file with .ino extension. Arduino gained much popularity which attributed to its distinctive features such as:

- Economical
- It can run in various platforms like Windows, Linux and Macintosh
- Programming environment is easy to comprehend
- Both software and hardware are open source and can be customized to meet specific need

In this project, the Arduino board will take input from ultrasonic sensor, calculate the distance to the obstacle and control rotation of the servo motor as an output response. The hardware is assembled to form the obstacle avoiding robot in Fig.4 with the help of a chassis, wheels and connecting cables.



**Fig. 4:** Side View of the Robot

## V. CONCLUSION

This project developed an obstacle avoiding robot to detect and avoid obstacles in its path. The robot is built on the Arduino platform for data processing and its software counterpart helped to communicate with the robot to send parameters for guiding movement. For obstacle detection, three ultrasonic distance sensors were used that provided a wider field of detection. The robot is fully autonomous and after the initial loading of the code, it requires no user intervention during its operation. When placed in unknown environment with obstacles, it moved while avoiding all obstacles with considerable accuracy.

The work done in this project can act as a base for further improvements to increase accuracy and adaptability of obstacle detection in diverse environments. In future, the authors of this project intend to test the feasibility of integrating different types of sensors to complement each other's disadvantages. For instance, imaging sensor can be beneficial when ultrasonic sensor may not correctly identify obstacles in environment subjected to ambient noise and varying temperature or air pressure. The accuracy of determining the distance to the obstacles can be increased by the inclusion of an electronic barometer for automatic adjustment of the speed of sound in air. Also the addition of a Bluetooth device can offer the flexibility of remotely changing control parameters in the code.

## REFERENCES

- [1]. Ahasan, M. A., Hossain, S. A., Siddiquee, A. U., & Rahman, M. M. (2015), "Obstacles Invariant Navigation of An Autonomous Robot based on GPS", Khulna University.
- [2]. Arduino. (2015). Arduino Software (IDE). (Arduino) Retrieved December 27, 2015, from <https://www.arduino.cc/en/Guide/Environment>
- [3]. Arduino. (2015). Introduction. (Arduino) Retrieved December 12, 2015, from <https://www.arduino.cc/en/Guide/Introduction>
- [4]. Duino-Robotics. (2013). Obstacle Avoidance Tutorial. (Duino-Robotics) Retrieved November 23, 2015, from <http://www.duino-robotics.com/obstacle-avoidance.html>
- [5]. Gray, K. W. (2000). Obstacle Detection and Avoidance for an Autonomous Farm Tractor. Utah State University.
- [6]. Heidarsson, H. K., & Sukhatme, G. S. (2011). Obstacle Detection and Avoidance for an Autonomous Surface Vehicle using a Profiling Sonar. 2011 IEEE International Conference on Robotics and Automation. Shanghai.
- [7]. Ryther, C. A., & Madsen, O. B. (2009). Obstacle Detection and Avoidance for Mobile Robots. Technical University of Denmark.
- [8]. Shahdib, F., Ullah, M. W., Hasan, M. K., & Mahmud, H. (2013). Obstacle Detection and Object Size